

METAL PICKET FENCE

TISA AND POLO VERTICAL

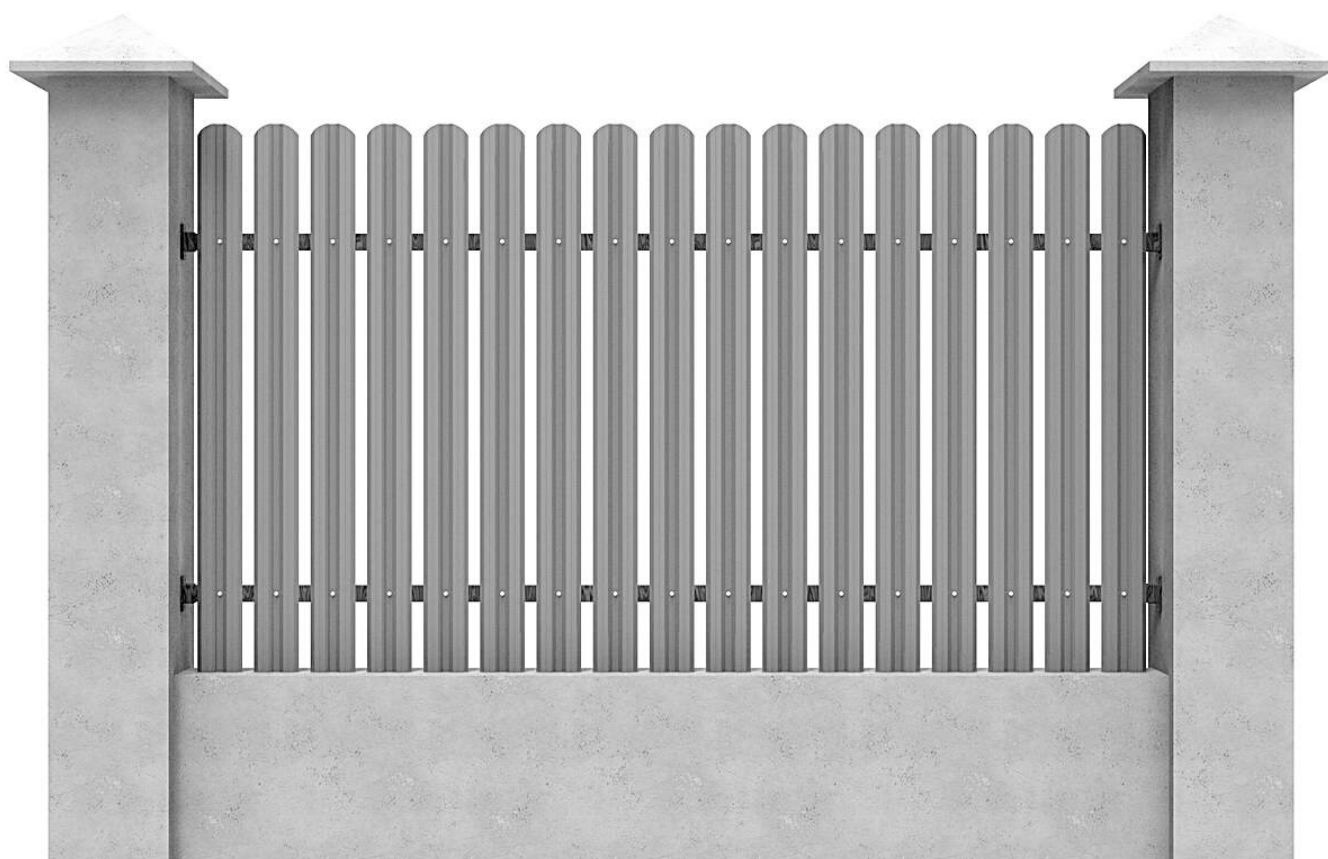

ASSEMBLY INSTRUCTIONS

INCLUDED ELEMENTS

SELF-DRILLING SCREWS

50 PCS. (h) PICKET \leq 1.50m

[the required quantity for fastening
in 2 fixing points / picket]

75 PCS. (h) PICKET $>$ 1.50m

[the required quantity for fastening
in 3 fixing points / picket]

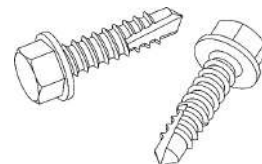

METAL PICKET TISA

25 PCS.

[the required necessary for approximately 3 meters of fence
with a distance of 1cm between pickets]

NECESSARY TOOLS

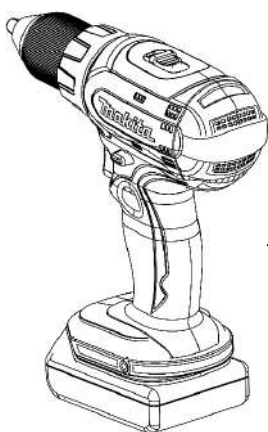

**SCREWDRIVER
MACHIE**

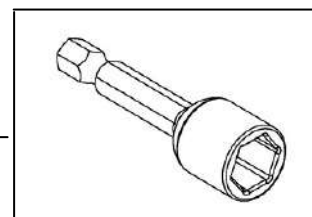

**Tubular Key
 \varnothing 8**

ASSEMBLY

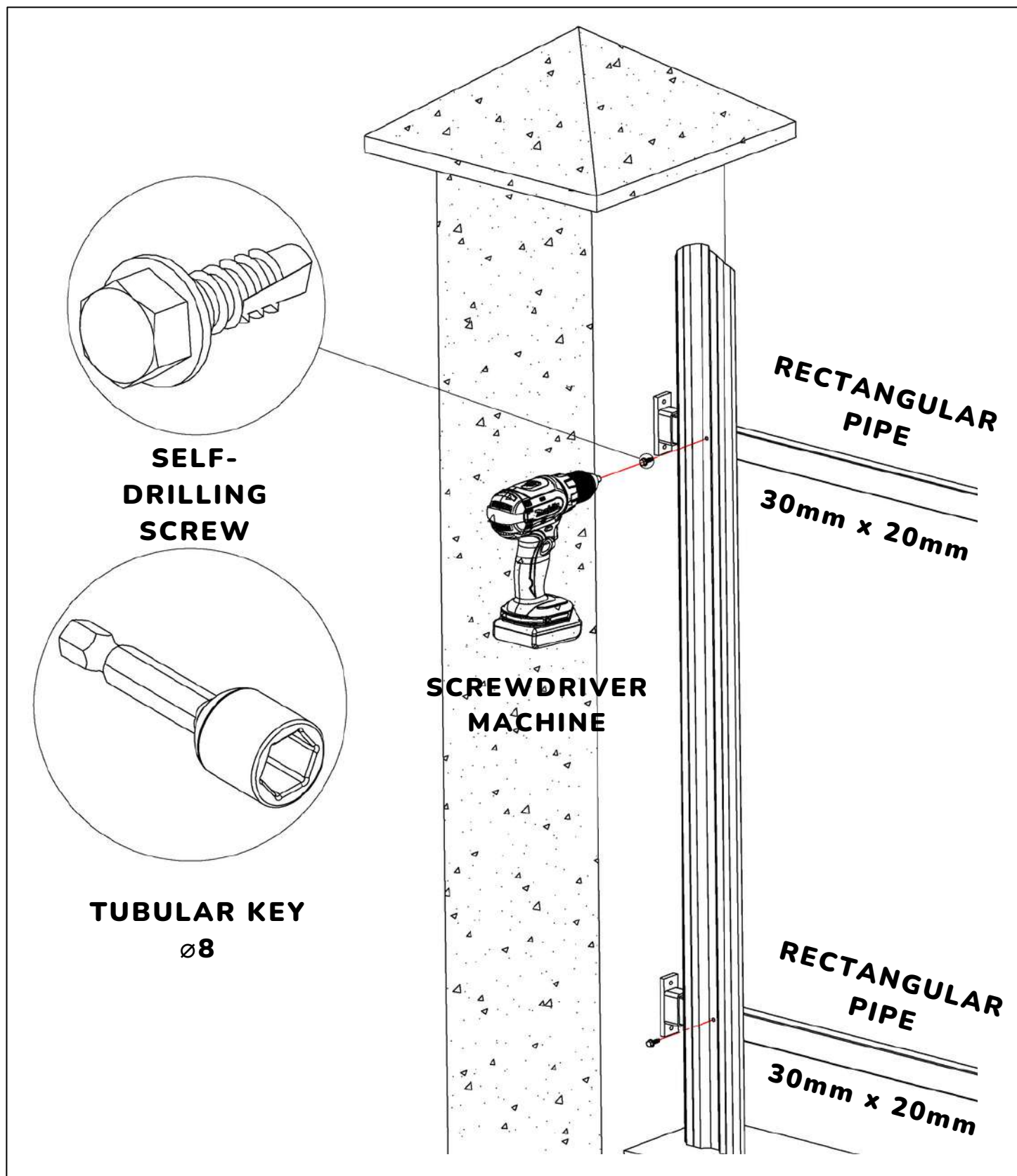

1 Position the Metal Picket vertically onto the metal rectangular pipes.

2 Using the Screwdriver Machine with a tubular key of 8, screw in the Metal Picket with the included self-drilling holes.



Hold the profiles firmly in place throughout the screwing process to prevent them from shifting or repositioning.

ferro system

ferrosystem.com
(425) 371 9121